

PHILOSOPHY
visionnaire

CHAIRS
and
STOOLS

dehors collection



Concepita come una collezione biennale 2020/2021, Beauty si rivela un progetto in continua evoluzione: oltre alle famiglie di prodotti con una dichiarata vocazione artistica e alle capsule collection di Art Design, sono due le nuove capsule che si fondono armoniosamente ad essa. Numerosi designer coinvolti e un nome che chiama in causa un tema ambizioso, quello della bellezza, da una parte intesa come sinonimo di positività e aspirazione, espressione di valori profondi, di contenuti significativi, di un sentire sensibile come la capacità di generare benessere nella persona, dall'altra un attributo più intrinseco, connesso alla singolarità e all'eccellenza dell'oggetto di design; una bellezza che nasce dalla sperimentazione sui materiali, dall'accostamento degli elementi, dalla sapienza degli artigiani capaci di testare e perfezionare nuove soluzioni materiche che rendono ogni singolo prodotto unico e non replicabile, seppur riproducibile.

BEAUTY

biennial collection

Conceived as a two-year collection for 2020/2021, Beauty turns out to be a constantly evolving project: in addition to product families with a declared artistic vocation and to the capsule collections of Art Design, there are two new capsules that blend harmoniously with it. Numerous involved designers and a name that calls into question an ambitious theme – that of beauty – taken as a synonym of positivity and hope, an expression of deeply rooted values and meaningful contents, a sensibility capable of generating personal wellbeing, but also as a more intrinsic attribute, connected with the uniqueness and excellence of the design object. A beauty that springs from experimentation with materials, the juxtaposition of elements, the skill of master artisans capable of developing and perfecting new material solutions that make every single product unique and irreplicable, although reproducible.

Visionnaire prosegue il suo percorso di sviluppo sostenibile, concependo i progetti installativi della Milano Design Week 2021 in un'ottica carbon neutral e plastic free, tutelando l'ambiente e andando a compensare le emissioni di CO2 prodotte durante gli eventi di settembre. Le emissioni dirette ed indirette sono state compensate tramite carbon credits (certificati VCS) generati da un progetto di riforestazione realizzato in Brasile, a Mato Grosso del Sud, e riconosciuti dalle Nazioni Unite.

Questo progetto è stato scelto perché racchiude i tre co-benefits più significativi: ambientale, sociale e di biodiversità.

Ambientale, perché la specie arborea piantata ha una straordinaria efficienza nell'assorbimento di CO2 e nella produzione di ossigeno e che permette quindi un uso efficiente del terreno inteso come risorsa scarsa.

Sociale, perché il progetto ha creato molteplici nuovi posti di lavoro per le comunità locali, offrendo ai lavoratori salari maggiori rispetto alla media, formazione e nuovi servizi di healthcare e wellbeing.

Biodiversità, perché prima di questo progetto, l'area era totalmente degradata a causa del pascolo intensivo e la riforestazione ha permesso di creare un nuovo ecosistema favorevole alla fauna, che ha trovato rifugio e cibo al suo interno (sono oltretutto presenti diverse specie animali considerati a rischio dalla Red List dello IUCN come l'ara giacinto, il crisocione, il formichiere gigante, l'armadillo gigante, il tapiro, il gattopardo, il puma ed il giaguaro).

Visionnaire è seguita in questo percorso da Carbon Credits Consulting, startup bolognese specializzata in progetti di carbon offsetting che offre consulenza alle organizzazioni sensibili alle problematiche ambientali.



CARBON NEUTRALITY

Visionnaire continues along its path of sustainable growth, conceiving the installation projects of Milan Design Week 2021 from a carbon neutral and plastic free perspective, protecting the environment and compensating for CO2 emissions during the September events. Direct and indirect emissions were offset by carbon credits (VCS certificates) generated by a reforestation project carried out in Brazil, in Mato Grosso del Sud, and recognized by the United Nations.

This project was chosen because it contains the three most significant co-benefits: environmental, social and biodiversity.

Environmental, because the planted tree species has an extraordinary efficiency in the absorption of CO2 and in the production of oxygen and which therefore allows an efficient use of the land intended as a scarce resource.

Social, because the project has created multiple new jobs for local communities, offering workers higher than average wages, training and new healthcare and wellbeing services.

Biodiversity, because before this project, the area was totally degraded due to intensive grazing and reforestation has made it possible to create a new ecosystem conducive to wildlife, who found shelter and food in it (*there are also several animal species considered at risk from the IUCN Red List such as the hyacinth macaw, the maned wolf, the giant anteater, the giant armadillo, the tapir, the leopard, the puma and the jaguar*).

Visionnaire is followed in this path by Carbon Credits Consulting, a start up from Bologna specialized in carbon offsetting projects that offers advice to organizations sensitive to environmental issues.



INDEX

ALBATROS

stool 14

CLEM

stool 20

chair 22

KYLO

PADDED

stool 28

chair 30

SUNNY

stool 38

chair 40

AMINTA

chair 46

ASTRID

chair 52

ELEANOR

chair 58

TANYA

chair 64

VANJA

chair 70

CONEY

ISLAND

chair 74

FARNESE

chair 78

La flessibilità per il cambiamento sarà un paradigma essenziale nel progetto architettonico e negli gli oggetti di design che sceglieremo e che diventeranno parte insostituibile delle nostre vite.

E' per questo motivo che Visionnaire ha scelto di presentare una selezione tra le sedie e gli sgabelli più iconici della sua collezione e che formalmente possono essere tradotti per un uso outdoor. Questi prodotti sono interamente realizzati con rivestimenti adatti agli spazi all'aperto.

*Pelli e tessuti altamente performanti che entreranno a far parte del nuovo **sample book Dehors**, che verrà presentato in anteprima durante la Milano Design Week 2021.*

The flexibility for change will be an essential paradigm in architectural design and the design objects that will choose and will become an irreplaceable part of our lives.

It is for this reason that Visionnaire has chosen to present a selection of the most iconic chairs and stools in its collection that can be formally translated for outdoor use. These products are entirely made with coatings suitable for outdoor spaces.

High-performance leathers and fabrics that will become part of the new **Dehors sample book**, which will be previewed during Milan Design Week 2021.



ALBATROS

The inspiration from the automotive world is clear in the Albatros stool. The structure is made of powder coated aluminum - in satin light gray - and supports a seat with linear and aerodynamic shapes.



ALBATROS

stool



ALBATROS

design Alessandro La Spada

45x42 H.95 cm

Supporting structure with footrest finished with Light Gray Otago YW263I powder coating. Main upholstery in Lasting leather 3067/120 Neve.



Lasting leather 3067/120 Neve



YW2631I Light Gray Otago

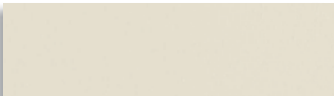

ALBATROS

technical drawings

Sgabello outdoor
Outdoor stool

Design
Alessandro La Spada

Sgabello con schienale, monosocca in legno multistrati curvato, con gambe in tubo metallico di acciaio inox. Rivestimento in pelle o tessuto con filetti sui bordi. Le parti in metallo sono disponibili nella selezione finiture metalliche oppure nella versione heavy-duty verniciato a polveri (per esterni).

Stool with small backrest, whole structure in curved plywood, with legs in stainless steel tube. Upholstery in leather or fabric and matching pipings on the edges. Metal parts can be lacquered in any colour included in the metal finish selection or in powder painting finishing.

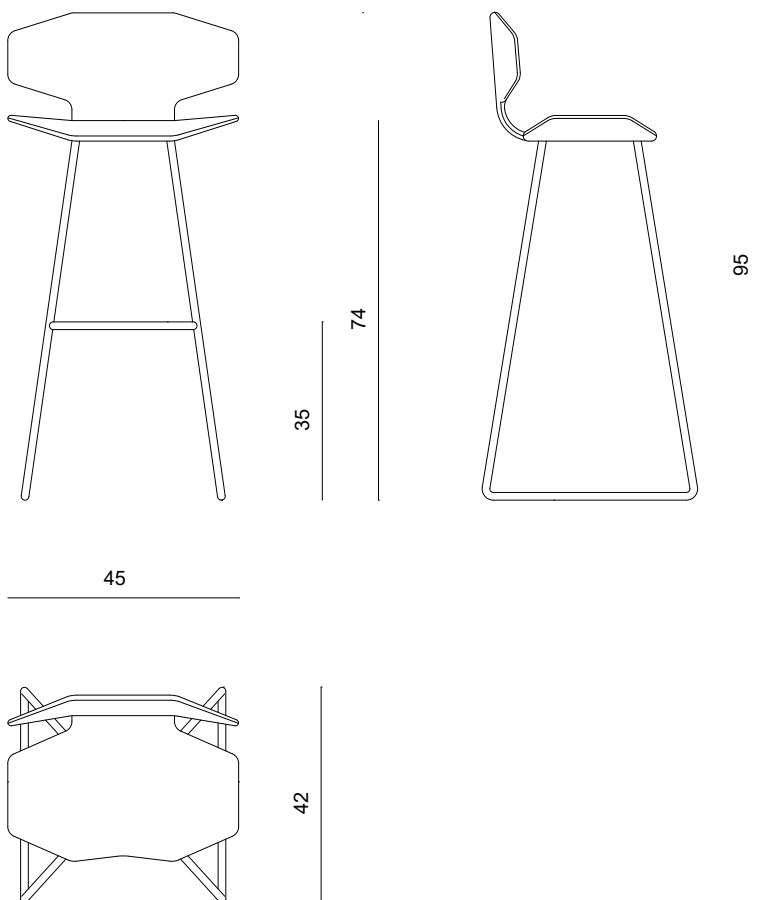





CLEM

CLEM

outdoor stool



CLEM
design Alessandro La Spada

60x59 H.96 cm

Seat and back upholstery in Extreme leather 3067/163 Sabbia.
Structure in tubular steel with satinized champagne finish.

Extreme leather 3067/163 Sabbia



Satinized champagne



CLEM

outdoor chair



CLEM
design Alessandro La Spada

60x59 H.77 cm

Seat and back upholstery in fabric Augusta 3045/20 Beige. Structure in tubular steel with satinized champagne finish.

Augusta 3045/20 Beige

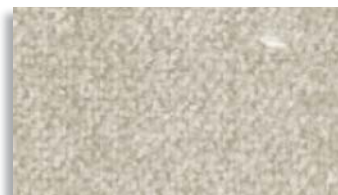

Satinized champagne





CLEM

technical drawings

Sgabello outdoor
Outdoor stool

Design
Alessandro La Spada

Telaio in tubo di ottone cromato a sezione quadra con logo Visionnaire inciso, poggiapiedi in acciaio inox, struttura di seduta e schienale in legno multistrato curvato, imbottito in poliuretano a densità differenziate e falda acrilica. Rivestimento fisso in pelle o tessuto della selezione outdoor. Le parti metalliche sono disponibili nella selezione finiture metalliche satinate. Versione heavy-duty con telaio e gambe verniciati a polveri (per esterni), consigliato per ambiente marino e nautica.

Frame in squared brass pipe with engraved Visionnaire logo, footrest in stainless steel, seat structure and backrest in curved plywood padded in polyurethane in different densities and acrylic fibre. Fixed upholstery in outdoor leather or fabric. Metal parts available in the satinized metal finishing selection. Heavy-duty version: frame and legs in powder painting, recommended for marine and nautical environment.

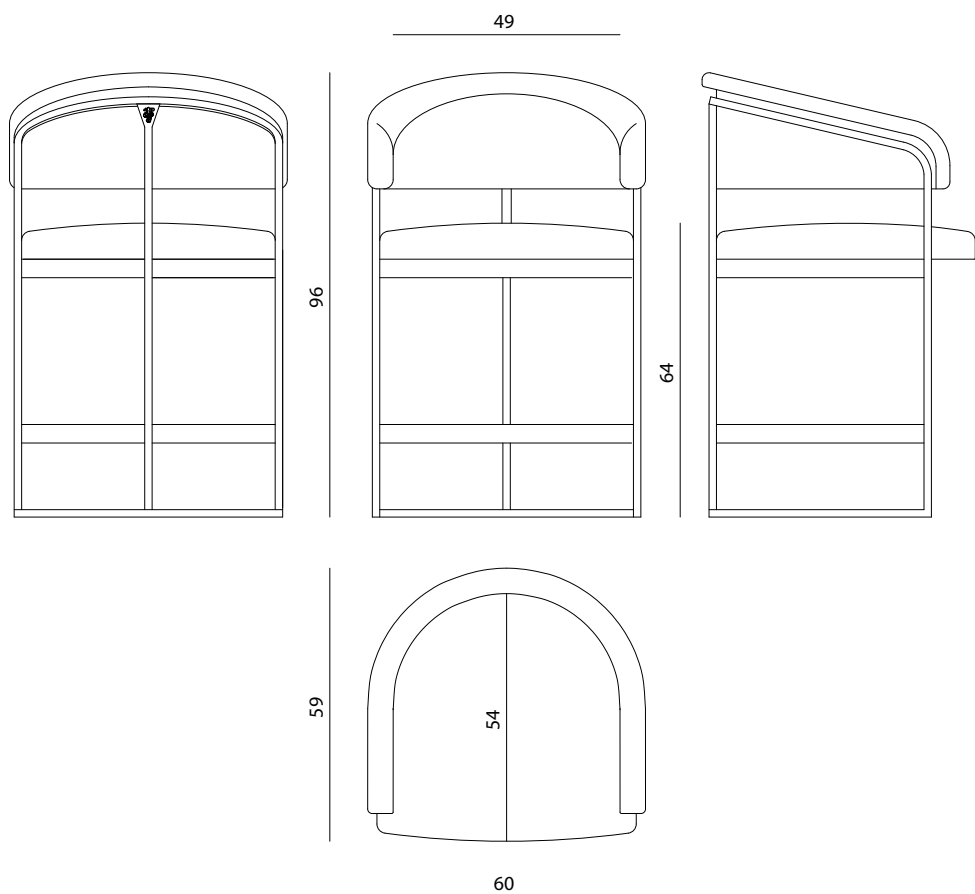

Sedia outdoor
Outdoor chair

Design
Alessandro La Spada

Telaio in tubo di ottone cromato a sezione quadra con logo Visionnaire inciso, struttura di seduta e schienale in legno multistrato curvato, imbottito in poliuretano a densità differenziate e falda acrilica. Rivestimento fisso in pelle o tessuto della selezione outdoor. Le parti metalliche sono disponibili nella selezione finiture metalliche satiniate. Versione heavy-duty con telaio e gambe verniciati a polveri (per esterni), consigliato per ambiente marino e nautica.

Frame in squared brass pipe with engraved Visionnaire logo, seat structure and backrest in curved plywood padded in polyurethane in different densities and acrylic fibre. Fixed upholstery in outdoor leather or fabric. Metal parts available in the satinized metal finishing selection. Heavy-duty version: frame and legs in powder painting, recommended for marine and nautical environment.

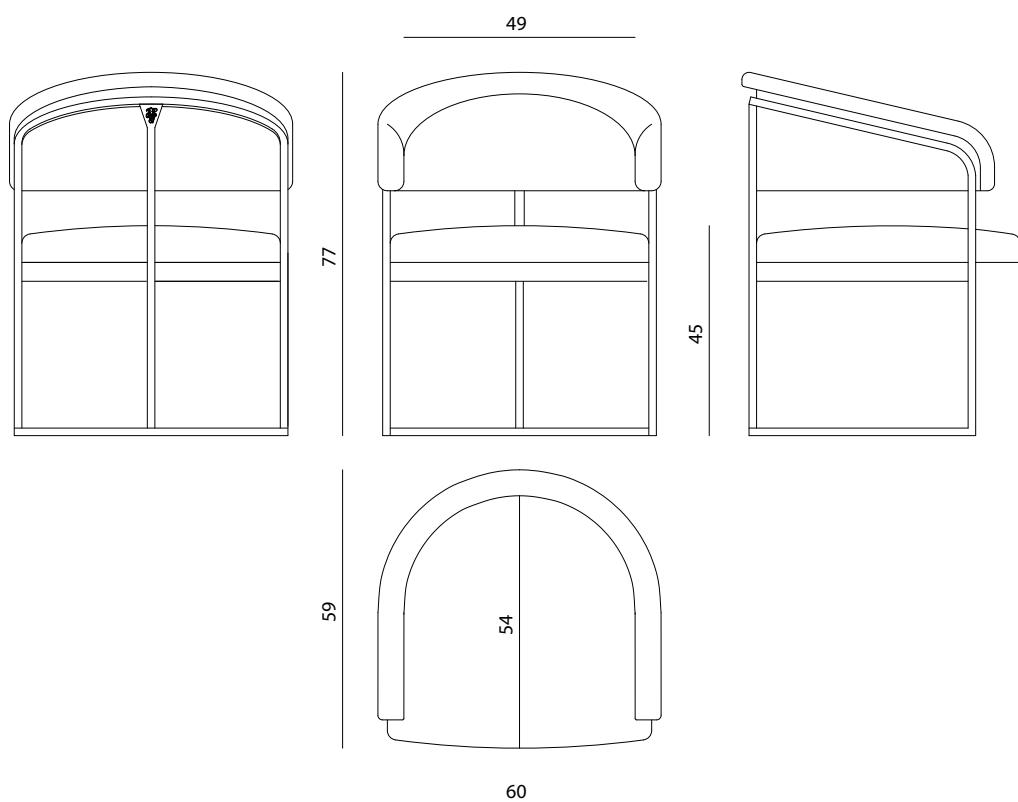



KYLO PADDED

KYLO PADDED

outdoor stool



KYLO PADDED

design Alessandro La Spada

57x62 H.103 cm

Stool in curved wood with quilted upholstery in Extreme Leather 3067/173 Creta. YW356F gris 2800 sablè powder coating legs in conic-shaped tubular metal and turned feet with polished Siena-lacquered finish.

Extreme Leather 3067/173 Creta



YW356F gris 2800 sablè



Lacquered siena



KYLO PADDED

outdoor chair



KYLO PADDED

design Alessandro La Spada

60x59 H.83 cm

Chair in curved wood with quilted upholstery in Augusta 3045/70 Noce fabric. YW356F gris 2800 sablè powder coating legs in conic-shaped tubular metal and turned feet with polished Siena-lacquered finish.

Augusta 3045/70 Noce



YW356F gris 2800 sablè

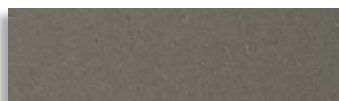

Lacquered siena



KYLO PADDED

outdoor chair



KYLO PADDED

design Alessandro La Spada

60x59 H.83 cm

Chair in curved wood with quilted upholstery in Augusta 3045/81 Avio. YW356F gris 2800 sablè powder coating legs in conic-shaped tubular metal and turned feet with polished Siena-lacquered finish.

Augusta 3045/81 Avio



YW356F gris 2800 sablè



Lacquered siena



KYLO PADDED

technical drawings

Sgabello outdoor
Outdoor stool

Design
Alessandro La Spada

Scocca in legno multistrati marino curvato, con gambe in tubo metallico conificato e piedi torniti. Tappezzeria trapuntata con rivestimento in pelle o tessuto della selezione outdoor e filetti sul bordo schienale nello stesso materiale. Il telaio è disponibile verniciato a polveri (per esterni), i puntali in metallo sono disponibili nella selezione finiture metalliche satinare.

External structure in curved marine plywood, with legs in conic metal tube and turned feet. Quilted upholstery in outdoor leather or fabric and matching pipings on the edges. Heavy-duty version: frame in powder painting, metal tips available in the satinized metal finishing selection.

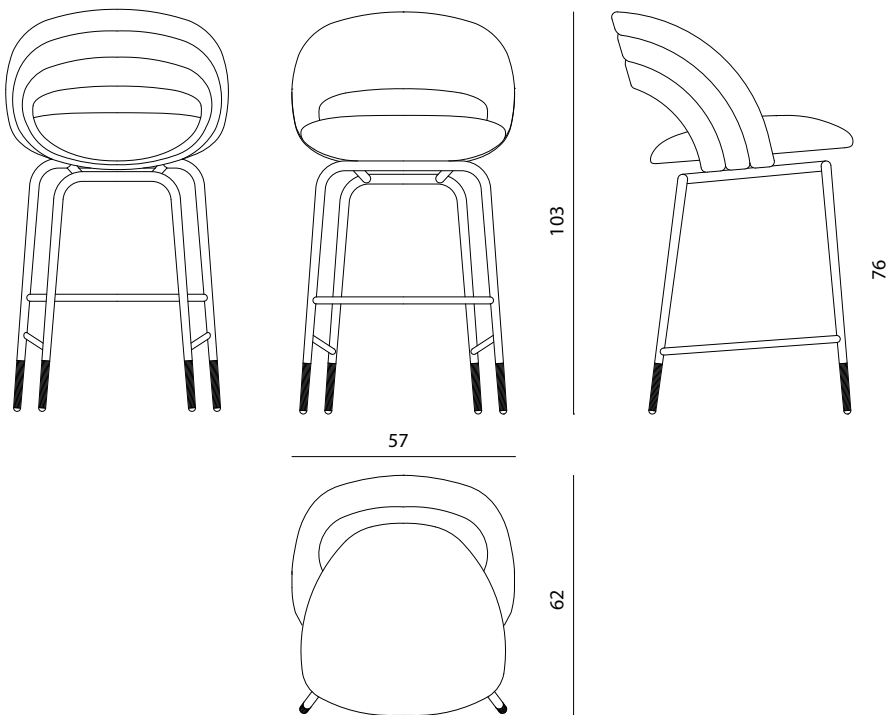

Sedia outdoor
Outdoor chair

Design
Alessandro La Spada

Sedia in legno multistrati marino curvato, con gambe in tubo metallico conificato e piedi torniti. Tappezzeria trapuntata con rivestimento in pelle o tessuto della selezione outdoor e filetti sul bordo schienale nello stesso materiale. Il telaio è disponibile verniciato a polveri (per esterni), i puntali in metallo sono disponibili nella selezione finiture metalliche satiniate.

Chair in curved marine plywood, legs in conic-shaped metal tube and turned feet. Quilted upholstery in outdoor leather or fabric and backrest piping in leather or fabric. Heavy-duty version: frame in powder painting, metal tips available in the satinized metal finishing selection.

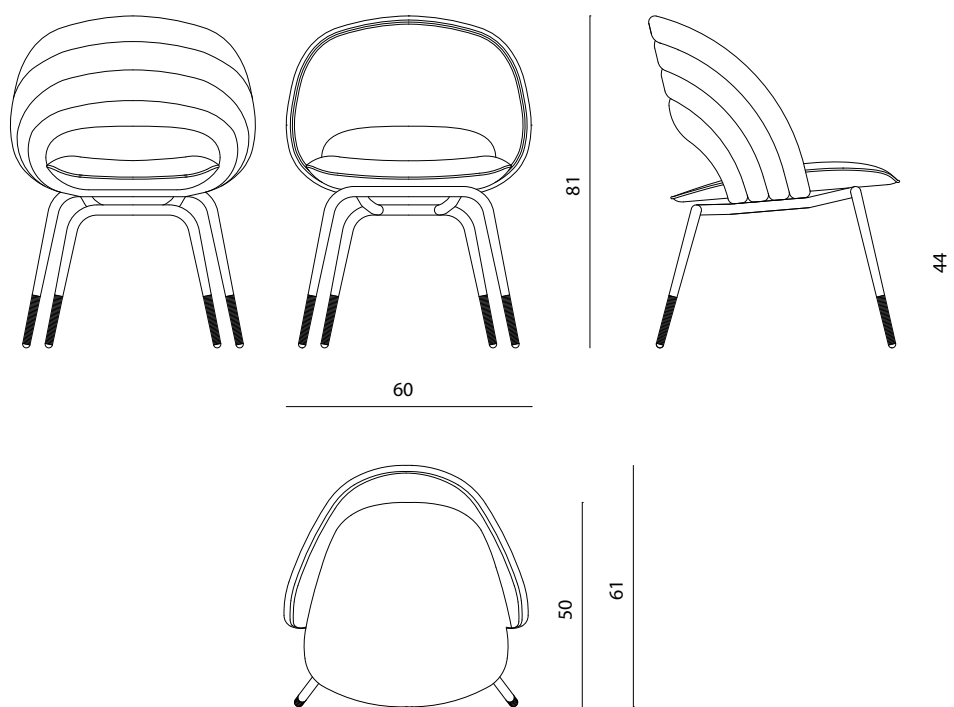



SUNNY

SUNNY

outdoor stool



SUNNY
design Alessandro La Spada

58x57 H.100 cm

Seat and back upholstery in Extreme Leather 3067/130 Beige.
Structure in tubular steel with satinized siena finish.

Extreme Leather 3067/130 Beige

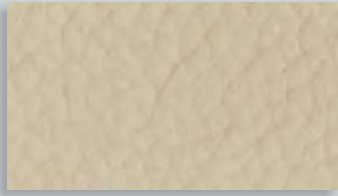

Satinized siena



SUNNY

outdoor chair



SUNNY

design Alessandro La Spada

59x59 H.74 cm

Seat and back upholstery in fabric Augusta 3045/50 Cammello.
Structure in tubular steel with satinized gold finish.

Augusta 3045/50 Cammello



Satinized gold



SUNNY

technical drawings

Sedia & sgabello outdoor
Outdoor chair & stool

Design
Alessandro La Spada

Sedia e sgabello imbottiti con telaio in acciaio inox lucidato, struttura dello schienale curvato e del sedile in multistrati. Imbottitura in poliuretano a densità differenziate. Rivestimento in pelle o tessuto. Le parti in metallo sono disponibili nella selezione finiture metalliche.

Upholstered armchair and stool with frame in polished stainless steel, structure of the curved backrest and seat in plywood. Padding in polyurethane in different densities. Main upholstery in leather or fabric. Metal parts available in the metal finishing selection.

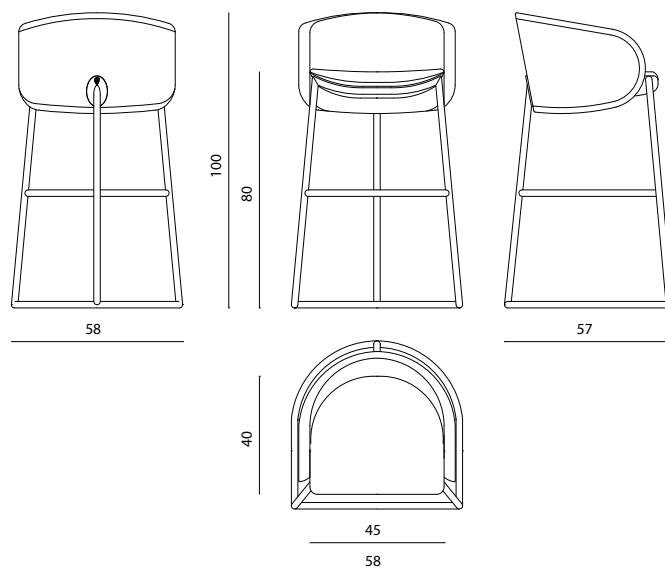
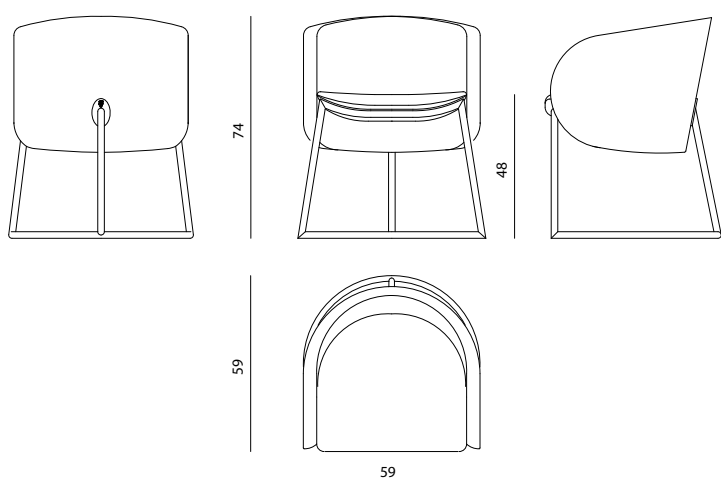

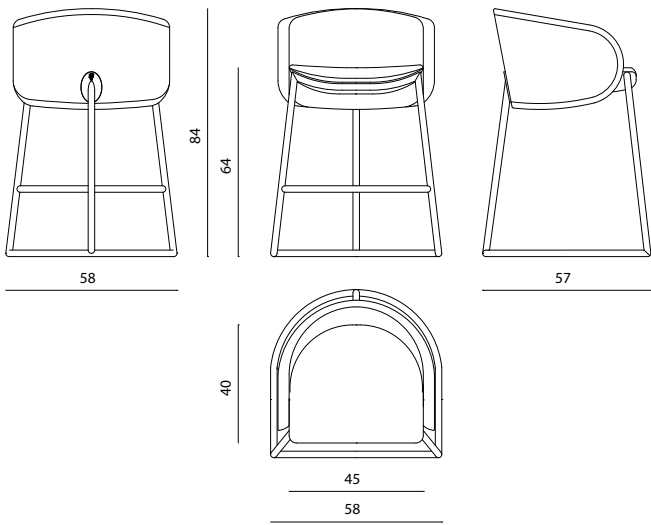



AMINTA

AMINTA

outdoor chair



AMINTA
design Giuseppe Viganò

58x54 H.72 cm

Main frame and tubular legs in satinized black nickel. Seat and internal back in fabric Augusta 3045/81 Avio.

Augusta 3045/81 Avio



Satinized black nickel



AMINTA

technical drawings

Sedia outdoor
Outdoor chair

Design
Giuseppe Viganò

Sedia in acciaio inox con seduta e cuscino volante di schienale tappezzati in pelle o tessuto outdoor. Sedile dotato di cinghie elastiche tappezzato e imbottito in poliuretano. Gambe in tubo conificato. Il telaio e le gambe sono disponibili nella selezione finiture metalliche lucide. Versione heavy-duty con telaio e gambe verniciati a polveri (per esterni), consigliato per ambiente marino e nautica.

Outdoor chair in stainless steel with upholstered seat and back loose cushion in leather or fabric (outdoor samples). Legs in polished tubular steel with conic section. Seat equipped with elastic spring belts, padded in polyurethane. The frame and legs can be lacquered in any colour included in the polish metal finish selection. Heavy-duty version: frame and legs in powder painting, recommended for marine and nautical environment.

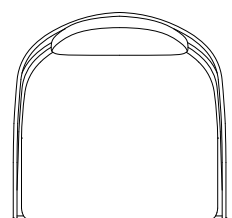
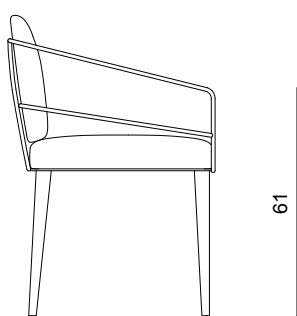
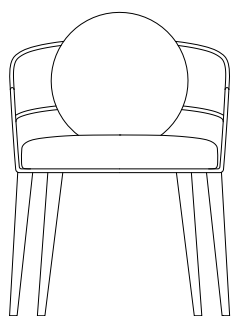
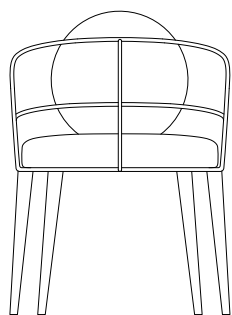

52

56

48

74

61

55



VISTORRA



ASTRID

ASTRID

outdoor chair



ASTRID
design Alessandro La Spada

58x54 H.72 cm

Seat, back and piping upholstered in Augusta 3045/17 Silver fabric.
Legs in satinized black nickel.

Augusta 3045/17 Silver

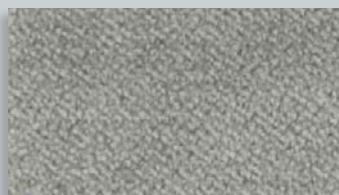

Satinized black nickel



ASTRID

technical drawings

Sedia outdoor
Outdoor chair

Design
Alessandro La Spada

Sedia imbottita con scocca in legno multistrati marino curvato, imbottita e rivestita in pelle o tessuto della selezione outdoor. Gambe in fusione di alluminio satinato disponibile nella selezione finiture metalliche oppure verniciato a polveri (per esterni). Lo schienale è disponibile anche nella versione "quilted" in pelle con ricamo con disegno foliage, leggermente imbottito.

Padded chair with curved marine plywood shell upholstered and covered in outdoor leather or fabric. Legs in aluminium cast available in the metal finishing selection or in powder painting finishing. The back is also available in the "quilted" version in leather with embroidery with a slightly padded, foliage design.

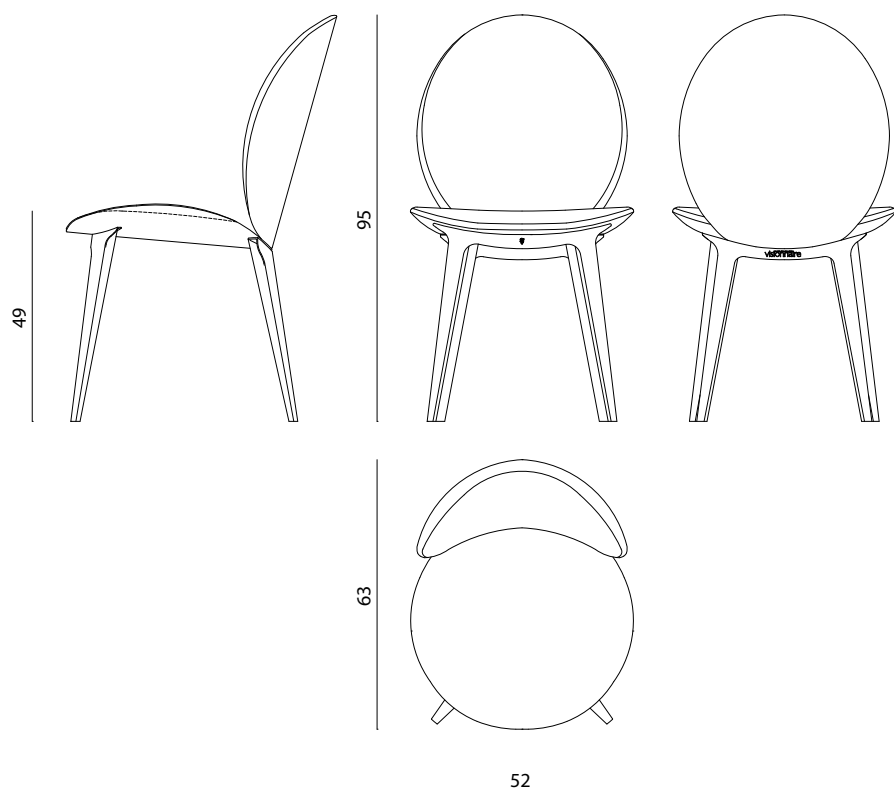







ELEANOR

ELEANOR

outdoor chair



ELEANOR
design Giuseppe Viganò

62x57 H.78 cm

Seat and back upholstery in Augusta 3045/11 Ghiaccio fabric.
Structure in tubular steel with lacquered gold finish.

Augusta 3045/11 Ghiaccio



Lacquered gold



ELEANOR

technical drawings

Sedia outdoor
Outdoor chair

Design
Giuseppe Viganò

Sedia in tubo di acciaio inox lucido curvato e saldato in unico pezzo, seduta e schienale imbottiti con anima in legno multistrato marino curvato e poliuretano incastonati nel telaio metallico rivestiti in pelle o tessuto della selezione outdoor. Il telaio è disponibile nelle finiture metalliche lucide oppure nella versione heavy-duty verniciato a polveri (per esterni).

Chair in shiny tubular metal curved and welded in one piece. Padded seat and backrest with structure in curved marine plywood and polyurethane, surrounded by tubular metal frame and upholstered in outdoor leather or fabric. The frame can be finished with any lacquer of the shiny metal lacquer finish selection or in powder painting finishing.

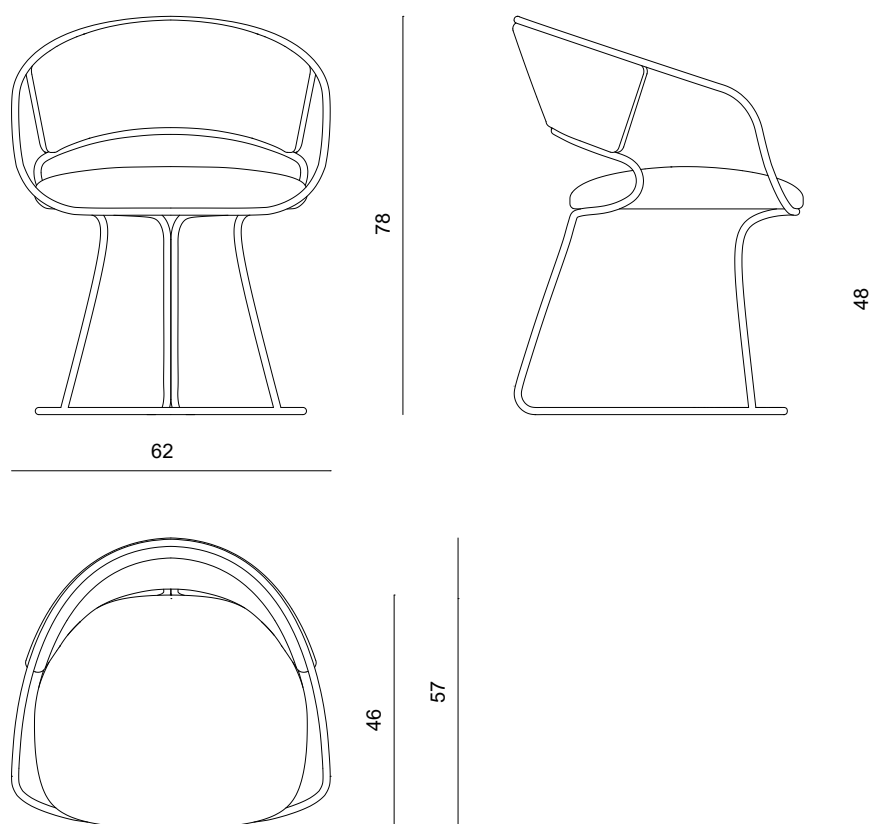







TANYA

TANYA

outdoor chair



TANYA
design Roberto Lazzeroni

60x52 H.80 cm

Seat and back in Augusta 3045/80 Azzurro fabric. Structure in YW360F noir sable powder coating.

Augusta 3045/80 Azzurro

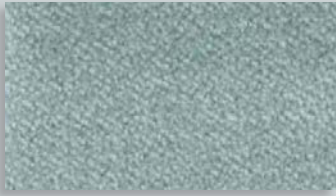

YW360F noir sablé



TANYA

technical drawings

Sedia e poltroncina outdoor
Outdoor chair & armchair

Design
Roberto Lazzeroni

Poltroncina e sedia monoscocca in poliuretano stampato a freddo con scocca interna in metallo. Rivestimento in pelle o tessuto della selezione outdoor; la parte esterna può essere rivestita in contrasto con la parte interna, divise da un filetto in pelle, tappezzeria rifinita sul retro con cucitura manuale. Gambe costituite da una singola struttura in fusione di alluminio, disponibile nella selezione vernici a polveri (per esterni) e piedini in acciaio inox, disponibili nella selezione finiture metalliche.

Armchair and chair in cold-cured PU Foam molding with internal metal shell. Upholstery in outdoor leather or fabric; the external part can be covered in contrast with the internal part, divided by a leather thread, upholstery finished on the back with manual stitching. Legs in aluminium cast, available in powder painting finishing and stainless steel feet, available in the metal finishing selection.

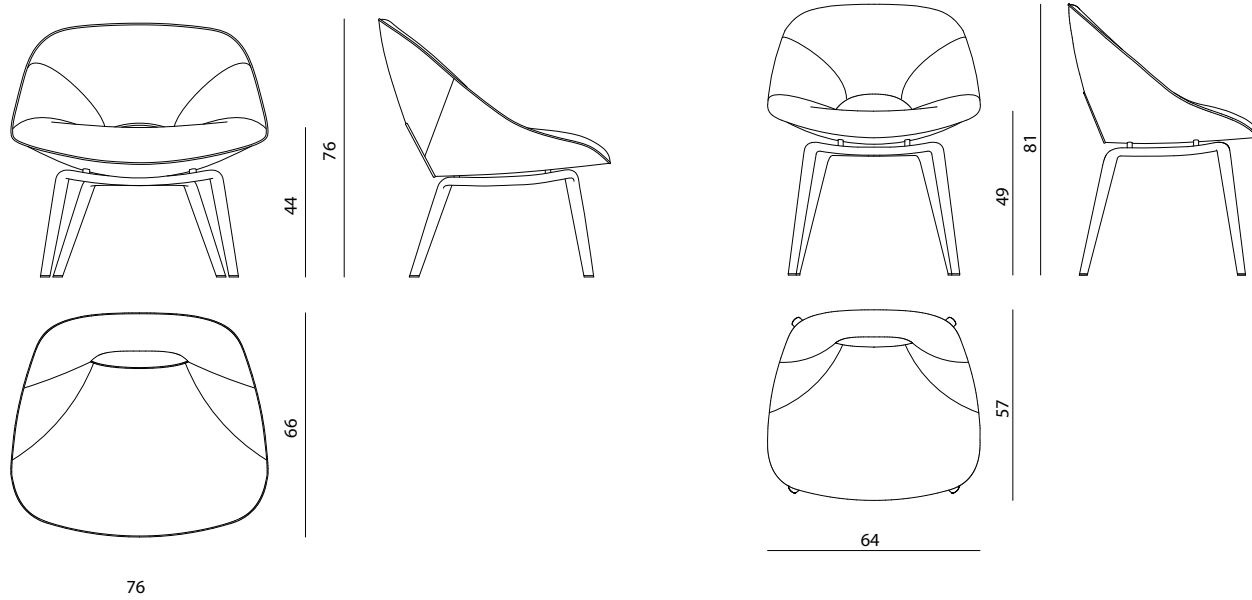







VANJA

VANJA

outdoor chair



VANJA
design Alessandro La Spada

57x65 H.77 cm

Seat and back upholstery in Augusta 3045/10 Neve fabric. Structure in YW263I Light Grey Otago, powder coating with finishings in lacquered gold.

Augusta 3045/10 Neve

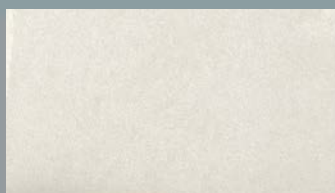

YW263I Light Gray Otago

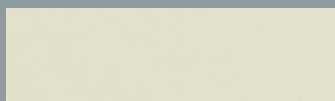

Lacquered gold



VANJA

technical drawings

Sedia outdoor
Outdoor chair

Design
Alessandro La Spada

Sedia in metallo protetto da fondo zincante e vernice a polveri (per esterni). Schienale e sedile in multistrato curvo con imbottitura in poliuretano a densità differenziate rivestito in falda acrilica. Rivestimento disponibile in pelle o tessuto da esterni.

Chair in metal covered by a protective bottom plate, galvanized and lacquered in powder painting finishing. Backrest and seat in curved plywood with padding in polyurethane in different densities covered in acrylic fibre. Upholstery available in waterproof leather or fabric.

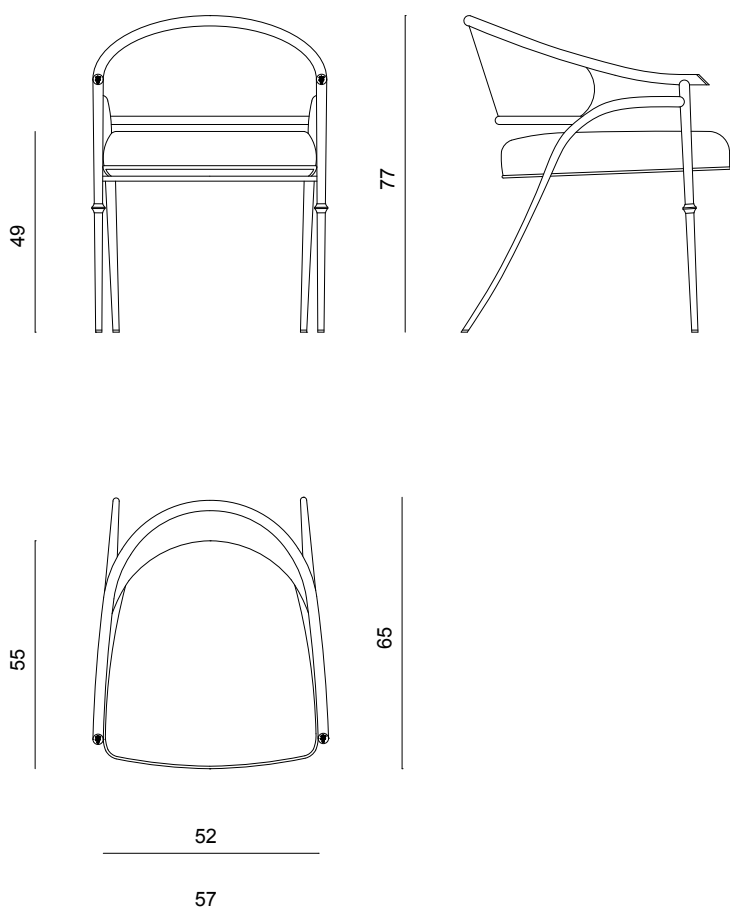



CONEY ISLAND

outdoor chair



CONEY ISLAND

design Samuele Mazza

73x75 H.75/92 cm

Upholstery in Rodi 3011/04 Ardesia fabric with Perseo PM.97 coordinated pipings. Structure in hand-woven synthetic rattan, bronze color, giving a “Vienna straw” pattern effect. Feet in golden finishing.

Rodi 3011/04 Ardesia



Lacquered gold



CONEY ISLAND

technical drawings

Sedia outdoor
Outdoor chair

Design
Samuele Mazza

Poltroncina in rattan sintetico intrecciato a mano con trama "paglia di Vienna" su telaio in traliccio di alluminio. Piedini in alluminio lucidato protetto da vernice trasparente, disponibili nella selezione finiture metalliche. Sedile imbottito in poliuretano e falda acrilica. Cuscino schienale in poliuretano elastico e falda acrilica. Rivestimento in tessuti outdoor con filetto in tinta. Il rattan sintetico è disponibile nei colori white gold, honey gold e bronze.

Chair in hand-woven synthetic rattan giving a "Vienna straw" pattern effect, frame in aluminium truss. Feet in polished aluminium with transparent protective coating, available with any lacquer of the metal lacquer finish selection. Back cushion in elastic polyurethane and acrylic fibre. Upholstery in outdoor fabric with pipings. Synthetic rattan is available in white gold, honey gold and bronze.

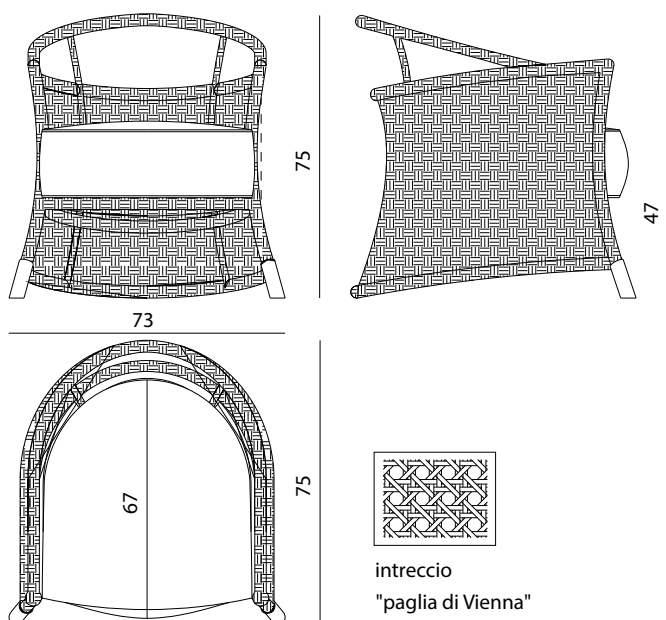



FARNESE

outdoor chair



FARNESE

design Samuele Mazza

73x75 H.76/92 cm

Cushions upholstered in Vertigo 3000/024 Avorio fabric and Plushy 3001/11 Cioccolato fabric pipings. Structure in Black 110 natural rattan and 102 Nocciola Tiglio ovals. Decorative metal elements in gold finishing.

Vertigo 3000/024 Avorio

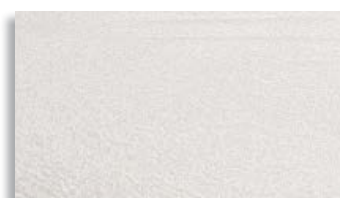

Lacquered gold





FARNESE

technical drawings

Sedia outdoor
Outdoor chair

Design
Samuele Mazza

Struttura portante realizzata in rattan naturale, legature in cuoio e fascette metalliche in acciaio inox lucido con incisione stemma araldico Visionnaire. Piano di seduta in multistrati marino. Cuscino di seduta in poliuretano elastico, con rinfascio in falda acrilica e foderatura di cotone. Cuscino di schienale in poliuretano elastico, con rinfascio in falda acrilica e foderatura di cotone. Elementi metallici decorativi tubolari disponibili nella selezione finiture metalliche, con logo Visionnaire. Rivestimento sfoderabile. Sconsigliato l'uso in ambienti completamente esposti alle intemperie.

Main structure in natural rattan, bindings in cuoio leather and metal clips in shiny stainless steel with Visionnaire engraved coat of arms. Seat support in marine plywood. Seat cushion in elastic polyurethane, with external acrylic layer with cover in cotton. Shaped back cushion in elastic polyurethane, with acrylic layer and cover in cotton. Decorative metal elements available in any colour included in the metal finish selection, with Visionnaire logo. Removable cover. Not recommended for use in environments completely exposed to the elements.

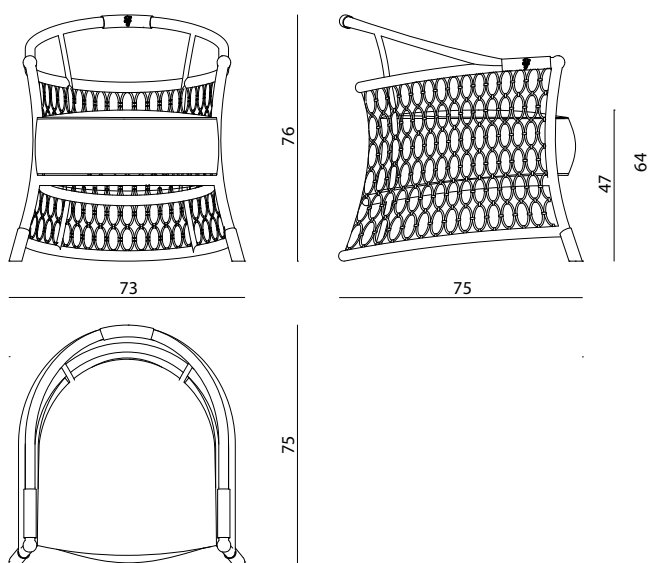



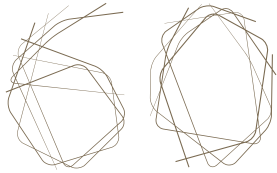

1959-2019

IPEI VISIONNAIRE
ANNIVERSARY

AWARDS

2021					
2020					
2019					
2018					
2017					



Produced by
©IPE SRL
ALL RIGHTS RESERVED

Visionnaire Logo, catalogue and advertising images are sole propriety of IPE srl, henceforth any use of the logo or adaptation of images is strictly forbidden without IPE srl prior approval; nonetheless, in any case the images must be used in such a way that there is no reasonable doubt that those belong to IPE srl and refer to IPE srl products. No part of this publication can be reproduced or transmitted in any form or by any means, both electronic or mechanical, including photocopying and recording, or via any information storage and retrieval system, without written permission of the publisher.

Made in Italy | September 2021

Art Director Eleonore Cavalli

Creatività, sostenibilità e meta-luxury.

La Re-Evolution dal cuore verde di Visionnaire passa anche dalla realizzazione di questo catalogo che unisce il valore storico dell'italianità del brand alla green consciousness. L'intero catalogo è stampato su carte ricavate da fonti gestite in maniera responsabile.

Creativity, sustainability and meta-luxury.

Visionnaire green-hearted re-evolution hits also the production of this catalogue, in which the long standing value of the company for made-in-Italy melts with the concept of green consciousness. The catalogue is printed on paper obtained from responsibly managed sources.



I.P.E. S.r.l.
Via Mattei 1 - 40069 Zola Predosa (Bo) Italy
tel. +39 051 6186311 - fax +39 051 6186310
www.visionnaire-home.com
ipe@ipe.it

Certificazioni relative a I.P.E. S.r.l.



The mark of
responsible forestry

Cerca i nostri prodotti
certificati FSC®

Look for our Products with
FSC® certification





