



HOME PHILOSOPHY
visionnaire
ARACEA



On the occasion of the Design Week in September 2021, Visionnaire will participate to Alcova, the traveling Kemesse of the Fuorisalone conceived by Joseph Grima and Valentina Ciuffi in 2018 and dedicated to designers, artists, galleries and institutions united by a pioneering vision of the culture of design, innovation and experimentation.

Alcova arrives this year in a former military area in the Inganni district. An abandoned urban forest and buildings from the 1930s invaded by uncontrolled vegetation are the ideal stage for the installation "De Rerum Natura" by Gunilla Zamboni, known as Gupica.

Aracea - design Gupica - is a sculptural lamp inspired by a liana with large heart-shaped leaves. It explores the concept of contemporary beauty through the metaphor of nature. Delicate and at the same time iconic presence, it is the result of a thought on the natural/artificial dichotomy as a constant/variant of the relationship between man and nature. Natural shapes are simplified until they became the components of a functional object. The LED light source, like lifeblood, passes through the central rib of the leaf producing a direct lighting also directable, simulating the natural movements of a leaf. Its modularity allows the declination in the floor, wall, table, suspension, sky/ground lamp models, all installed on the first floor of the "Casa delle Suore" between walls with printed velvet curtains and carpets with laser cut leaves made of recycled leathers on design by Gunilla Zamboni.

Visionnaire continues along its path of sustainable growth, conceiving the installation projects of Milan Design Week 2021 from a **carbon neutral** and **plastic free** perspective, protecting the environment and compensating for CO² emissions during the September events. Direct and indirect emissions were offset by carbon credits (VCS certificates) generated by a reforestation project carried out in Brazil, in Mato Grosso del Sud, and recognized by the United Nations.

This project was chosen because it contains the three most significant co-benefits: **environmental, social and biodiversity**.

Environmental, because the planted tree species has an extraordinary efficiency in the absorption of CO² and in the production of oxygen and which therefore allows an efficient use of the land intended as a scarce resource.

Social, because the project has created multiple new jobs for local communities, offering workers higher than average wages, training and new healthcare and wellbeing services.

Biodiversity, because before this project, the area was totally degraded due to intensive grazing and reforestation has made it possible to create a new ecosystem conducive to wildlife, who found shelter and food in it (*there are also several animal species considered at risk from the IUCN Red List such as the hyacinth macaw, the maned wolf, the giant anteater, the giant armadillo, the tapir, the leopard, the puma and the jaguar*).

Visionnaire is followed in this path by Carbon Credits Consulting, a Bolognese startup specialized in carbon offsetting projects that offers advice to organizations sensitive to environmental issues.







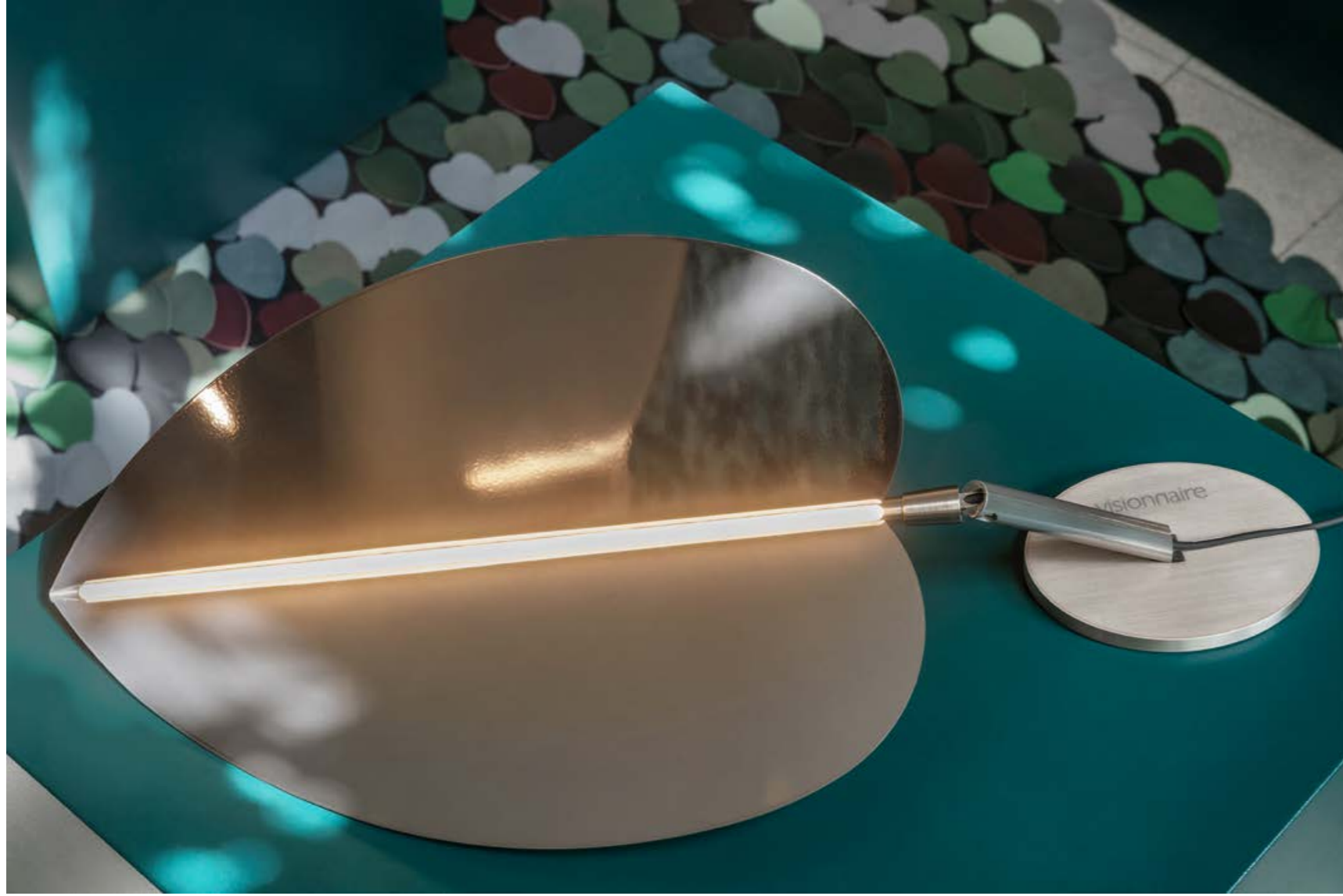

ARACEA
lightings



ARACEA
design Gupica

suspension lamp 81x61 H.206 cm

Suspension lamp in metal with satin Siena lacquered finish with leaves-shaped directional lights in steel with polished Siena-lacquered finish and linear LED source.

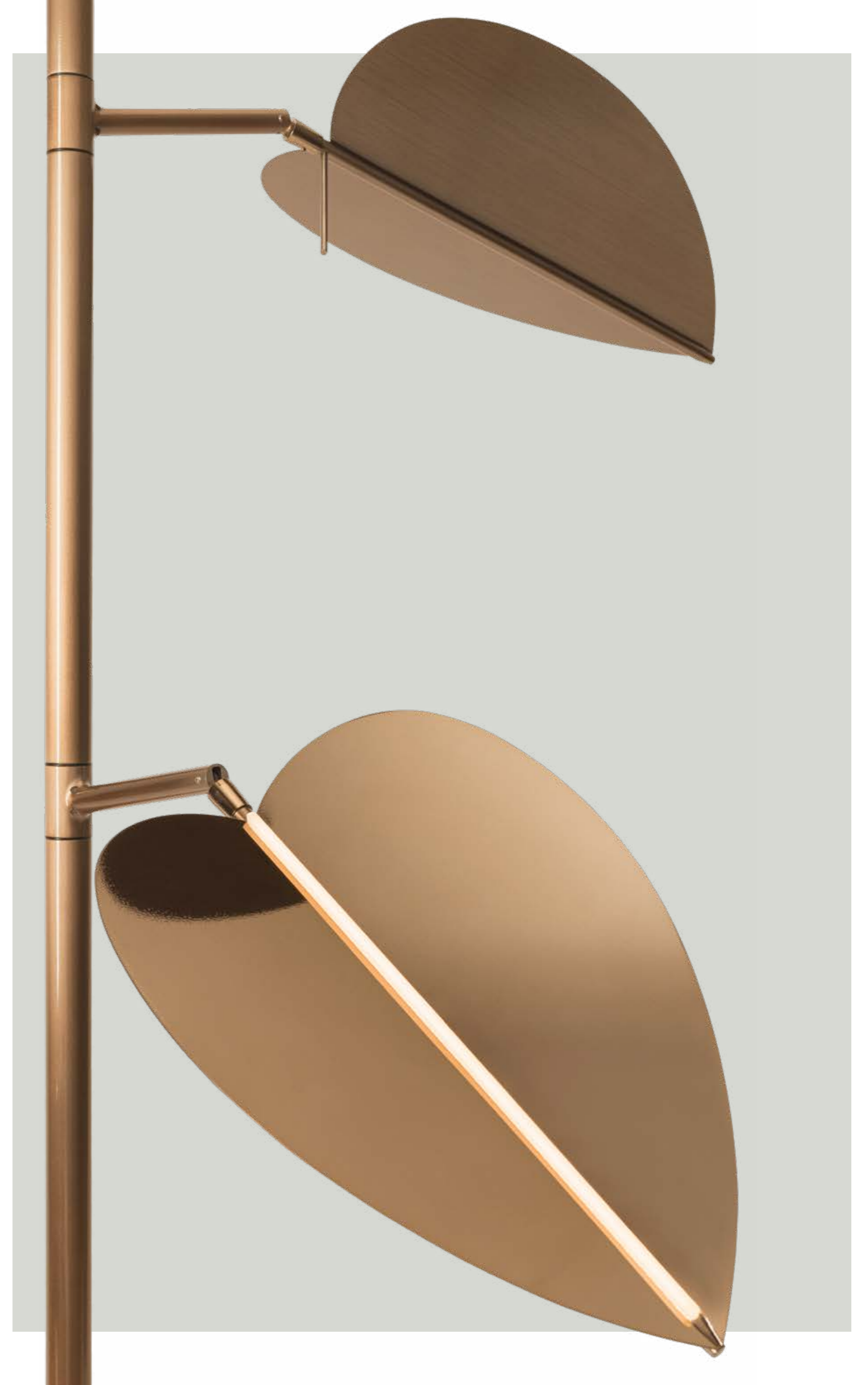



ARACEA
design Gupica

7 leaves ceiling attached floor lamp 85x76 H.264 cm

Floor to ceiling lamp in metal with satin Siena lacquered finish with leaves-shaped directional lights in steel with polished Siena-lacquered finish and linear LED source.





ARACEA
design Gupica

floor lamp 81x61 H.204 cm

Floor lamp in metal with satin Siena lacquered finish with leaves-shaped directional lights in steel with polished Siena-lacquered finish and linear LED source.





ARACEA
design Gupica

table lamp with stem with one leaf 59x25 H.53 cm
table lamp with stem and two leaves 91x30 H.79 cm

Table lamp in metal with satin Siena lacquered finish with leaves-shaped directional lights in steel with polished Siena-lacquered finish and linear LED source.





ARACEA
design Gupica

table lamp with one leaf 44x20 H.13 cm

Table lamp in metal with satin Siena lacquered finish with leaves-shaped directional lights in steel with polished Siena-lacquered finish and linear LED source.





ARACEA
design Gupica

wall lamp with three leaves 80x48 H.104 cm

Wall lamp in metal with satin Siena lacquered finish with leaves-shaped directional lights in steel with polished Siena-lacquered finish and linear LED source.



ARACEA

technical drawings

Lampadario a sospensione
Ceiling lamp

Design
Gupica

Sospensione in ottone e alluminio satinato con quattro luci "a foglia" in acciaio inox. Sorgente luminosa lineare a LED. Tutte le "foglie" sono regolabili sia nell'inclinazione che nella rotazione. Disponibile nella selezione finiture metalliche, la faccia superiore della foglia in finitura lucida e quella inferiore satinata. Potenza assorbita 12W, peso 25 kg. Questo modello monta sorgenti luminose a LED a lunga durata integrate nella struttura della lampada, non sostituibili dall'utente.

Suspended lamp in brass and satin aluminium with four "leaf-shaped" lights in stainless steel. Linear LED light source. The rotation and the inclination of all the leaves can be adjusted. Available in any lacquer included in the metal finish selection, the upper face of the "leaf" in polished finish and the lower face in satin finish. Absorbtion power 12W, weight 25 kg. This model is equipped with long-life LED light sources integrated into the lamp structure, which cannot be replaced by the user.

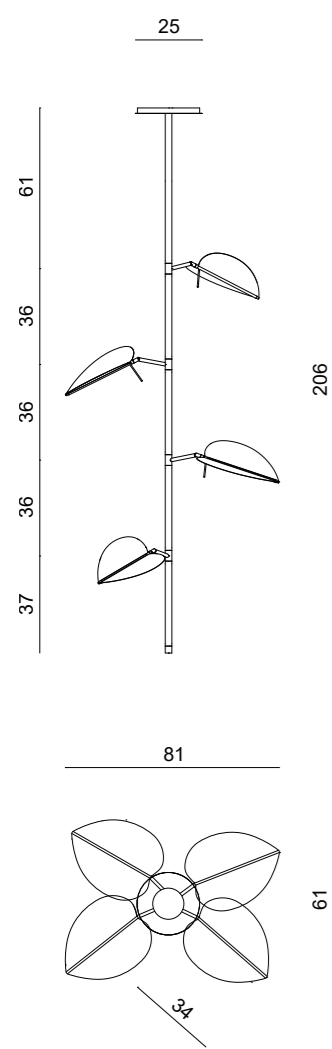

Lampada cielo-terra
Floor to ceiling lamp

Struttura in ottone e alluminio satinato con cinque luci "a foglia" in acciaio inox. Sorgente luminosa lineare a LED. Tutte le "foglie" sono regolabili sia nell'inclinazione che nella rotazione. Disponibile nella selezione finiture metalliche, la faccia superiore della foglia in finitura lucida e quella inferiore satinata. Potenza assorbita 15W, peso 30 kg. Questo modello monta sorgenti luminose a LED a lunga durata integrate nella struttura della lampada, non sostituibili dall'utente.

Structure in brass and satin aluminium with five "leaf-shaped" lights in stainless steel. Linear LED light source. The rotation and the inclination of all the leaves can be adjusted. Available in any lacquer included in the metal finish selection, the upper face of the "leaf" in polished finish and the lower face in satin finish. Absorbtion power 15W, weight 30 kg. This model is equipped with long-life LED light sources integrated into the lamp structure, which cannot be replaced by the user.

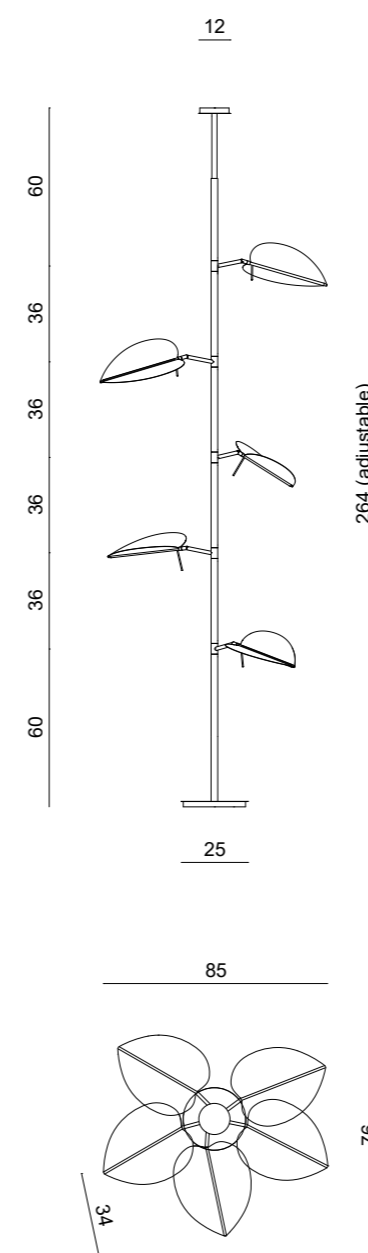

ARACEA

technical drawings

Lampada da terra
Floor lamp

Struttura in ottone e alluminio satinato con quattro luci "a foglia" in acciaio inox. Sorgente luminosa lineare a LED. Tutte le "foglie" sono regolabili sia nell'inclinazione che nella rotazione. Disponibile nella selezione finiture metalliche, la faccia superiore della foglia in finitura lucida e quella inferiore satinata. Potenza assorbita 12W, peso 20 kg. Questo modello monta sorgenti luminose a LED a lunga durata integrate nella struttura della lampada, non sostituibili dall'utente.

Structure in brass and satin aluminium with four "leaf-shaped" lights in stainless steel. Linear LED light source. The rotation and the inclination of all the leaves can be adjusted. Available in any lacquer included in the metal finish selection, the upper face of the "leaf" in polished finish and the lower face in satin finish. Absorption power 12W, weight 20 kg. This model is equipped with long-life LED light sources integrated into the lamp structure, which cannot be replaced by the user.

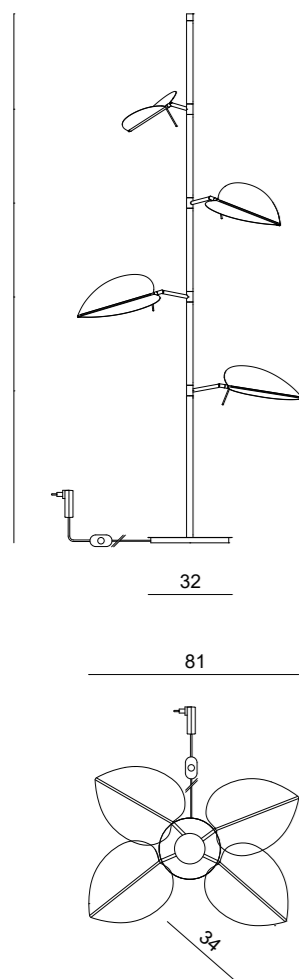

Lampada da tavolo
Table lamp

Struttura in ottone e alluminio satinato con luci "a foglia" in acciaio inox. Sorgente luminosa lineare a LED, con interruttore touch dimmerabile sulla base. Le "foglie" sono regolabili sia nell'inclinazione che nella rotazione. Disponibile nella selezione finiture metalliche, la faccia superiore della foglia in finitura lucida e quella inferiore satinata. Disponibile in versione a foglia singola o doppia. Potenza assorbita 6W, peso 7 kg (versione a due foglie), 3W, peso 5 kg (versione a foglia singola), 3W, peso 1 kg (versione a foglia singola da appoggio). Questo modello monta sorgenti luminose a LED a lunga durata integrate nella struttura della lampada, non sostituibili dall'utente.

Structure in brass and satin aluminium with four "leaf-shaped" lights in stainless steel. Linear LED light source with dimmable touch switch on the base. The rotation and the inclination of all the leaves can be adjusted. Available in any lacquer included in the metal finish selection, the upper face of the "leaf" in polished finish and the lower face in satin finish. Available in single leaf or double leaf version. Absorption power 6W, weight 7 kg (double leaf version), 3W, weight 5 kg (single leaf version), 3W, weight 1 kg (single leaf countertop version). This model is equipped with long-life LED light sources integrated into the lamp structure, which cannot be replaced by the user.

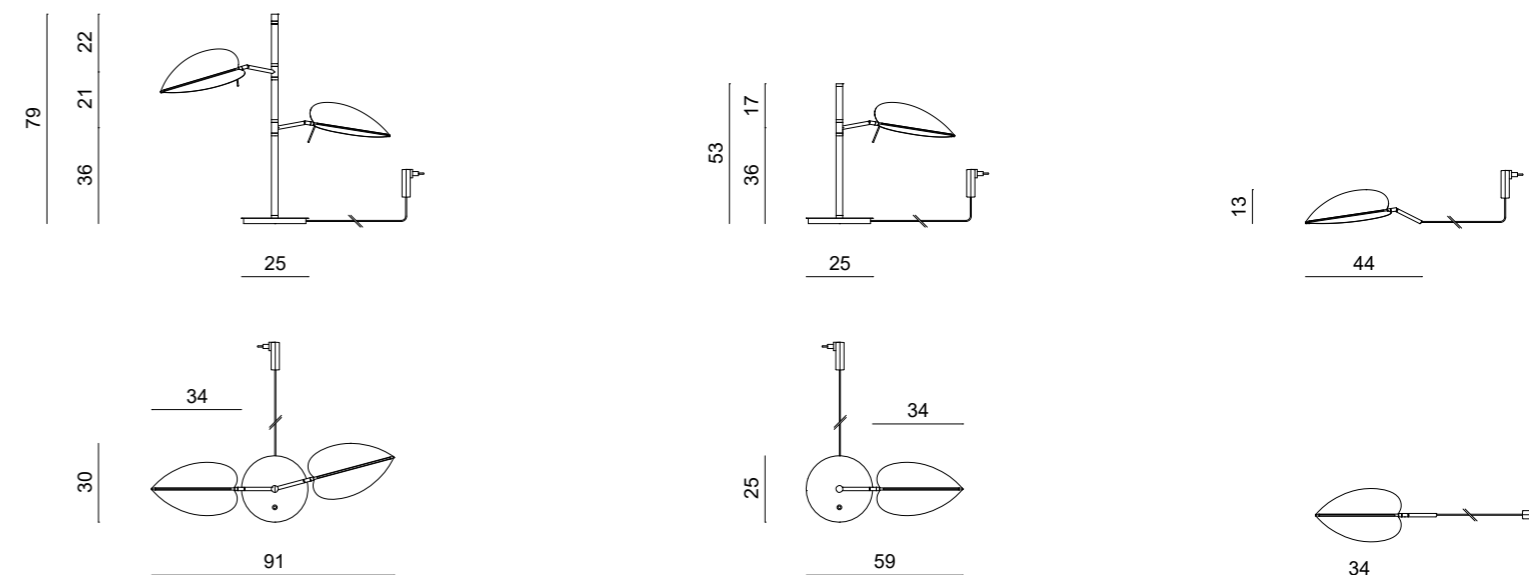

ARACEA

technical drawings

Applique
Wall lamp

Struttura in ottone e alluminio satinato con luci "a foglia" in acciaio inox. Sorgente luminosa lineare a LED. Tutte le "foglie" sono regolabili sia nell'inclinazione che nella rotazione. Disponibile nella selezione finiture metalliche, la faccia superiore della foglia in finitura lucida e quella inferiore satinata. Disponibile in versione a due foglie (potenza assorbita 6W, peso 8 kg), a tre foglie (potenza 9W, peso 10 kg) ed a due foglie predisposta per fissaggio sulla testata del letto (potenza 6W, peso 10 kg). Questo modello monta sorgenti luminose a LED a lunga durata integrate nella struttura della lampada, non sostituibili dall'utente.

Structure in brass and satin aluminium with four "leaf-shaped" lights in stainless steel. Linear LED light source. The rotation and the inclination of all the leaves can be adjusted. Base in satin metal. Available in any lacquer included in the metal finish selection, the upper face of the "leaf" in polished finish and the lower face in satin finish. Available in two leaves or three leaves version (absorbption power 6W, weight 8 kg; power 9W, weight 10 kg) and two leaves version predisposed to fix to headboard bed (power 6W, weight 10 kg). This model is equipped with long-life LED light sources integrated into the lamp structure, which cannot be replaced by the user.

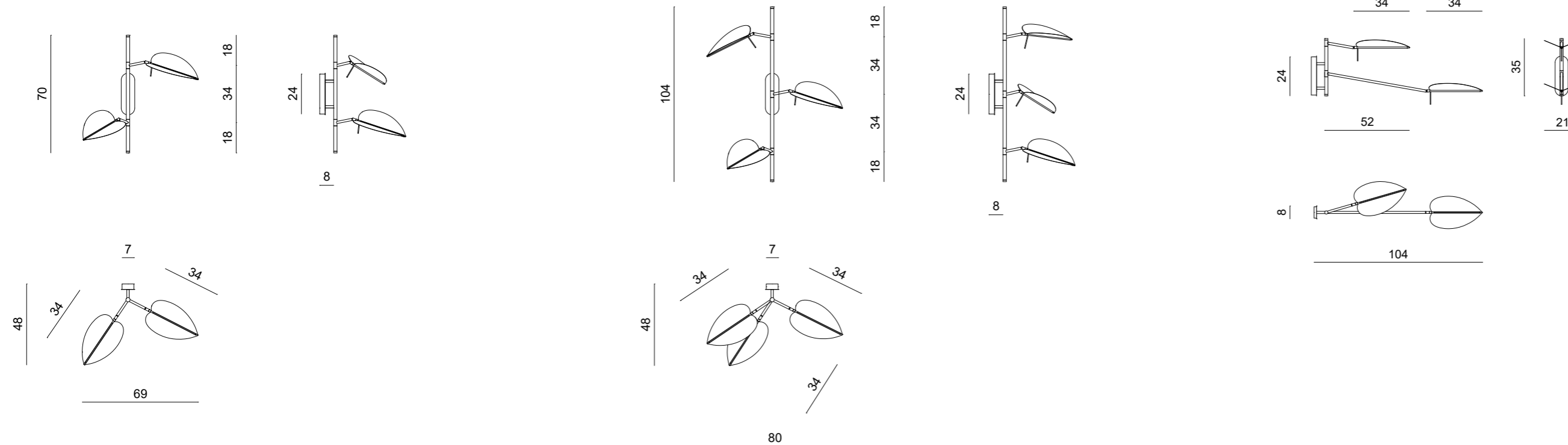



1959-2019

IPE | VISIONNAIRE
ANNIVERSARY



Produced by
©IPE SRL
ALL RIGHTS RESERVED

Visionnaire Logo, catalogue and advertising images are sole propriety of IPE srl, henceforth any use of the logo or adaptation of images is strictly forbidden without IPE srl prior approval; nonetheless, in any case the images must be used in such a way that there is no reasonable doubt that those belong to IPE srl and refer to IPE srl products. No part of this publication can be reproduced or transmitted in any form or by any means, both electronic or mechanical, including photocopying and recording, or via any information storage and retrieval system, without written permission of the publisher.

Made in Italy | September 2021

Art Director Eleonore Cavalli

Creatività, sostenibilità e meta-luxury.
La Re-Evolution dal cuore verde di Visionnaire passa anche dalla realizzazione di questo catalogo che unisce il valore storico dell'italianità del brand alla green consciousness. L'intero catalogo è stampato su carte ricavate da fonti gestite in maniera responsabile.

*Creativity, sustainability and meta-luxury.
Visionnaire green-hearted re-evolution hits also the production of this catalogue, in which the long standing value of the company for made-in-Italy melts with the concept of green consciousness. The catalogue is printed on paper obtained from responsibly managed sources.*



AWARDS

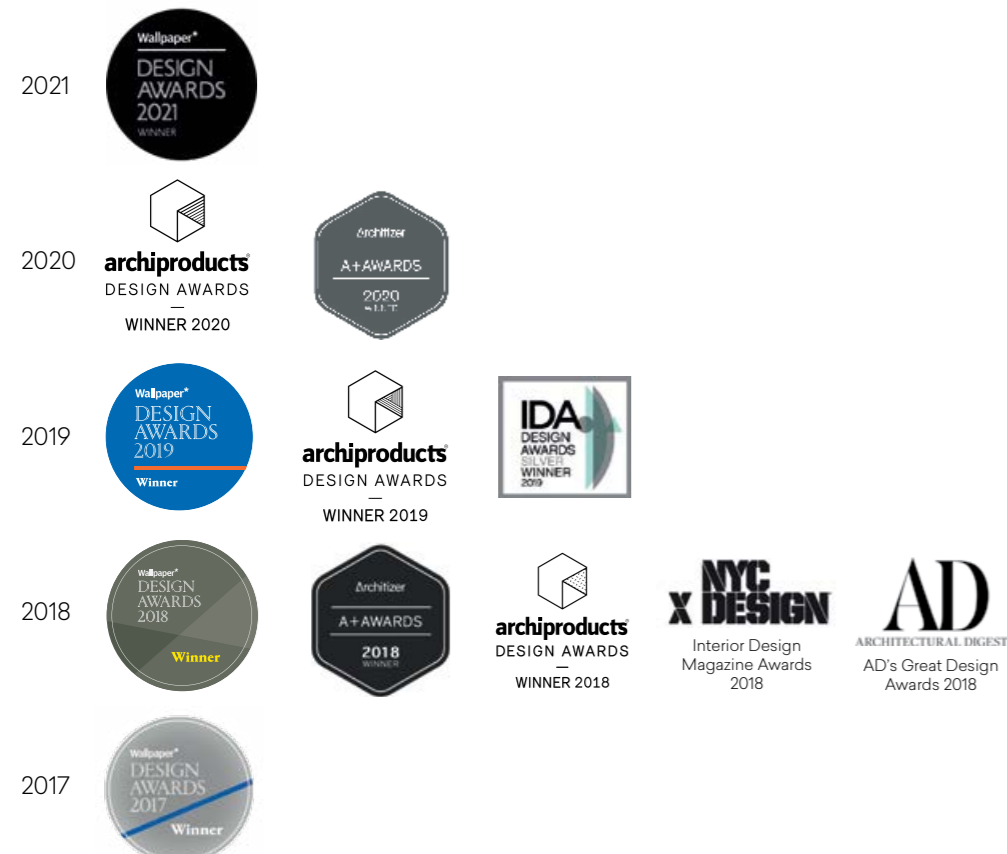

I.P.E. S.r.l.
Via Mattei 1 - 40069 Zola Predosa (Bo) Italy
tel. +39 051 6186311 - fax +39 051 6186310
www.visionnaire-home.com
ipe@ipe.it

Certificazioni relative a I.P.E. S.r.l.



The mark of
responsible forestry



Cerca i nostri prodotti
certificati FSC®
Look for our Products with
FSC® certification

